

FO01/FO02 FLOW SWITCH

INSTALLATION AND OPERATIONS MANUAL

90° Angle Flow Switch



SOLUTIONS WITH INNOVATION

AN INNOVATIVE SENSING COMPANY

ISO 9001:2008 CERTIFIED



READ THIS MANUAL PRIOR TO INSTALLATION

This manual provides information on the **F001 & F002 90° Angle Flow Switches**. It is important that all instructions are read carefully and followed sequentially. The **QuickStart Installation** instructions are a brief guide to the sequence of steps for experienced technicians to follow when installing the equipment. Detailed instructions are included in the **Complete Installation** section of this manual.

Conventions Used in this Manual

Certain conventions are used in this manual to convey specific types of information. General technical material, support data and safety information are presented in narrative form. The following styles are used for notes, cautions and warnings:

Notes

Notes contain information that augments or clarifies an operating step. Notes do not normally contain actions and often follow the procedural steps to which they refer.

Cautions

Cautions alert the technician to special conditions that could injure personnel, damage equipment, or reduce a component's mechanical integrity. Cautions are also used to alert the technician of unsafe practices, the need for special protective equipment, or specific materials. In this manual, a caution indicates a potentially hazardous situation which, if not avoided, may result in minor to moderate injury.

Warnings

Warnings identify potentially dangerous situations, or serious hazards. In this manual, a warning indicates an imminently hazardous situation which, if not avoided, may result in serious injury or death.

Safety Messages

Follow all standard industry procedures for servicing electrical and computer equipment when working with, or around high voltage. Always shut off the power supply before touching any components. Although high voltage is not present in this system, it may be present in other systems.

If the equipment is used in a manner not specified by the manufacturer, protection provided by equipment may be impaired.

Notice of Copyright and Limitations

Copyright © 2015 Solutions With Innovation, LLC;
All rights reserved.

Solutions With Innovation reserves the right to make changes to the product described in this manual at any time without notice. Solutions With Innovation makes no warranty with respect to the accuracy of the information in this manual.

Warranty

All Solutions With Innovation Electronic Level and Flow Controls are warranted free of defects in materials and workmanship for one full year from the date of the original factory shipment. If returned within the warranty period; and, upon factory inspection of the control, the cause of the claim is determined to be covered under the warranty; then, Solutions With Innovation will repair or replace the product at no cost to the purchaser (or owner) other than transportation.

Solutions With Innovation shall not be liable for misapplication, labor claims, direct or consequential damage, or expenses arising from the installation or use of the equipment. There are no other warranties expressed or implied, except special written warranties covering specific Solutions With Innovation products.

Quality Assurance

The Quality Assurance System in place at Solutions With Innovation guarantees the highest level of quality throughout the company. Solutions With Innovation is committed to providing full customer satisfaction; both in quality products and in quality service.

Contacts

Phone: 203-729-6434 *Mon-Fri, 9 AM - 5 PM EST*
Fax: 203-729-0541 *for General Inquiries*
Email: sales@innovativesensing.com

FO01/FO02 FLOW SWITCH

90° Angle Switch

TABLE OF CONTENTS

1.0 Quickstart Installation

1.1 Getting Started.....	4
1.1.1 Equipment and Tools.....	4
1.1.2 Configuration Information.....	4

2.0 Complete Installation

2.1 Unpacking.....	5
2.2 Installation Location.....	5
2.3 Before You Begin.....	5
2.3.1 Site Preparation.....	5
2.3.2 Equipment and Tools.....	5
2.4 Mounting.....	6
2.4.1 Installing the Switch.....	6
2.5 Wiring.....	7
2.5.1 General Purpose Wiring.....	7

3.0 Preventative Maintenance

3.1 What To Do.....	8
3.1.1 Inspect Entire Unit Periodically.....	8
3.1.2 Inspect Connections Monthly.....	8
3.1.3 Keep Unit Clean.....	8
3.2 What To Avoid.....	8

4.0 Reference Information

4.1 Description.....	9
4.2 Theory of Operation.....	9
4.3 Troubleshooting.....	9
4.3.1 Flow Switch Problems.....	9
4.4 Agency Approvals.....	10
4.5 Specifications.....	10
4.5.1 Functional Specifications.....	10
4.5.2 Dimensional Specifications.....	11
4.6 Model Configurator.....	12
4.7 Notes.....	13



1.0 QUICKSTART INSTALLATION

The Quickstart Installation procedures provide key steps for mounting, wiring and configuring the F001/F002 Flow Switches. These procedures are intended for experienced installers of electronic level measurement instruments. Refer to **Section 2.0: Complete Installation** for detailed installation instructions.

1.1 GETTING STARTED

Before beginning the Quickstart Installation procedures, have the proper equipment, tools and information readily available.

1.1.1 Equipment and Tools

- Open-End Wrenches or An Adjustable Wrench to Fit the Process Connection Size and Type

1.1.2 Configuration Information

The standard F001 and F002 90° Angle Flow Switch models are factory-calibrated devices. Therefore, field calibration is not required.

2.0 COMPLETE INSTALLATION

This section provides detailed procedures on properly installing the F001 & F002 90° Angle Flow Switches.

 **CAUTION!** IF THE EQUIPMENT IS USED IN A MANNER NOT SPECIFIED BY THE MANUFACTURER, PROTECTION PROVIDED BY THE EQUIPMENT MAY BE IMPAIRED.

2.1 UNPACKING

Unpack the instrument, carefully. Make sure that all components have been removed from the packing material. Inspect all components for damage. Report any concealed damage to the carrier within 24 hours of receiving. Compare the contents with the packing slip and report any discrepancies to the factory immediately. Record the sales order number and/or serial number for future reference when ordering parts.

Before Proceeding to Installation, Complete the Following:

- Inspect all components for damage. Report any damage to the carrier within 24 hours of receiving.
- Record the model and serial numbers for future reference when ordering parts.

Model Number _____

Serial Number _____

2.2 INSTALLATION LOCATION

The F001 & F002 90° Angle Flow Switches should be located within easy access for service and monitoring. Flow switches should not be exposed to ambient temperatures below -40° F (-40° C) or above +300° F (+148° C). Special precaution should be made to prevent exposure to corrosive atmospheres, excessive vibration, shock and physical damage.

2.3 BEFORE YOU BEGIN

2.3.1 Site Preparation

- 1 Each F001 and F002 Flow Switch is built according to the specifications indicated during the ordering process. Make sure that the connection is correct for the threaded mounting on the vessel or pipe where the flow switch will be placed. Refer to **Section 2.4: Mounting**.
- 2 Ensure that the wiring for the F001 & F002 Flow Switches are complete and correct for the type of installation. Refer to **Section 4.5: Specifications**.
- 3 When installing the F001 & F002 Flow Switches in a general purpose area, all local, state and federal regulations/guidelines must be observed. Refer to **Section 2.5: Wiring**.

2.3.2 Equipment and Tools

No special equipment or tools are required to install the F001 & F002 90° Angle Flow Switches.

The Following Are Recommended:

- Open-End Wrenches or An Adjustable Wrench to Fit the Process Connection Size and Type

2.4 MOUNTING

The F001 and F002 90° Angle Flow Switches are mounted using a threaded process connection. These devices are meant to be installed vertically with the inlet port facing downward. Contact the manufacturer for additional mounting options.

2.4.1 Installing the Switch

⚠ WARNING! DO NOT DISASSEMBLE THE FLOW SWITCH WHEN IT IS IN SERVICE AND/OR UNDER PRESSURE.

Before Proceeding:

- Verify that the flow switch has adequate room for installation.
- Verify that the process temperature, pressure and viscosity are within the designated ranges of the flow switch model.

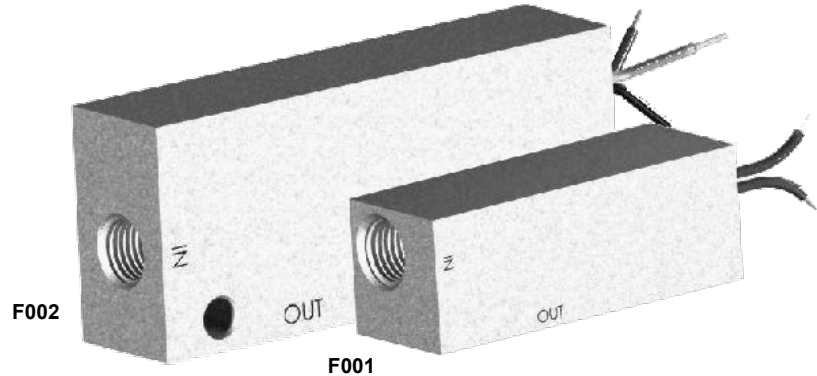

How to Install a F001 or F002 90° Angle Flow Switch:

- 1 Apply a minimal amount of either Teflon[®] tape or an appropriate thread sealant to the mounting threads to seal the connections.
- 2 Align the flow switch's process connection with the threaded mounting on the application.
- 3 Verify that the media's flow direction corresponds to the "in" and "out" port body markings. The flow switch only operates in one flow direction. *The flow switch will not operate in the reverse flow direction.*
- 4 Tighten the flow switch's process connections by hand.
- 5 Use an open-end or adjustable wrench to tighten the process connections 1 to 2 additional turns (for port orientation).

2.5 WIRING

CAUTION! OBSERVE ALL APPLICABLE ELECTRICAL CODES AND PROPER WIRING PROCEDURES.

2.5.1 General Purpose Wiring

- A General Purpose Installation does not have flammable media present.
- Power must be shut off before attempting to wire the device.

How to Install General Purpose Wiring:

SPST Reed Switch:

1 Connect the wiring to the red switch leads, as illustrated below.

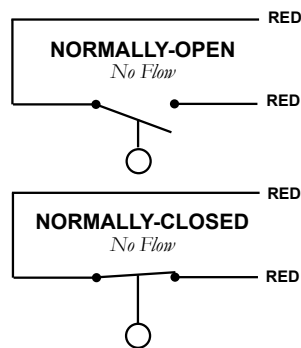

SPDT Reed Switch:

1 Connect the wiring to the proper switch leads, as illustrated below.

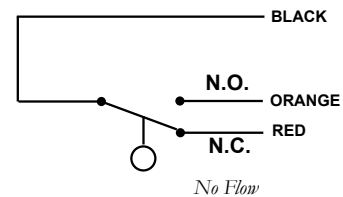

Contact Protection:

In order to maintain the life and reliability of the internal reed switch, it is essential to provide protection when switching inductive loads. When the current breaks, the energy stored in the load generates a high frequency voltage across the switch contacts. If the voltage is large enough, it can initiate arcing and cause the contacts to weld together. Damage can ultimately be prevented by suppressing the voltage. Through the use of a diode for DC circuits and a resistor-capacitor network for AC circuits, contact protection will ensure reliable performance from the reed switch.

3.0 PREVENTATIVE MAINTENANCE

Periodic inspections are necessary to maintain the proper functionality of the F001/F002 Flow Switches. The switches are a safety device that protects the equipment they serve. A systematic program of preventative maintenance should be implemented at the time of installation. If the following instructions are completed routinely, the switches will provide continuous, reliable protection.

3.1 MAINTENANCE PROCEDURES

3.1.1 Inspect Unit Periodically

Verify that there are no cracks or chipped surfaces on the switch's housing. Should the unit become damaged, obtain a replacement immediately.

3.1.2 Inspect Connections Monthly

F001 & F002 Flow Switches may be vulnerable to excessive heat and moisture. Under these conditions, the electrical wire insulation can periodically break or peel away. As a result, the bare wires may become exposed to the elements and incur damages.

- Inspect all wiring, carefully and replace any wires exhibiting signs of brittle insulation.
- Inspect all electrical connections to ensure tightness.
- Repair or replace any wiring, if necessary.

3.1.3 Keep Unit Clean

Periodic cleanings of the inlet and outlet ports will ensure the continual, uninterrupted movement of the mechanism. Always keep the flow ports clean and free of any potential interferences. Objects and debris may cause systematic interruptions and a loss in equipment functionality.

3.2 WHAT TO AVOID



NEVER LEAVE THE SWITCH WIRING EXPOSED TO THE ELEMENTS.



NEVER PLACE A JUMPER WIRE ACROSS THE TERMINALS TO “CUT-OUT” THE CONTROL. *If a jumper is necessary for testing purposes, ensure that it is removed prior to placing the control into service.*



NEVER USE IN SYSTEMS CONTAINING IRON PARTICLES. *The magnet within the piston assembly can attract the particles and become jammed.*

4.0 REFERENCE INFORMATION

This section illustrates an overview of the F001 & F002 90° Angle Flow Switches, as well as information on troubleshooting common problems, agency approval listings, and detailed physical, functional and performance specifications.

4.1 DESCRIPTION

F001 & F002 90° Angle Flow Switches are cost-effective devices installed in-line with the application's fluid movement to monitor flow rates in gallons per minute (GPM). Their compact and durable two-part assembly is comprised of an all-brass or all-stainless steel body with an internal piston. Motion is limited to the piston and with a simplified design, there are no bellows, diaphragms or mechanical linkages to wear, bind or cause in-service problems.

4.2 THEORY OF OPERATION

A spring-loaded magnetic piston inside the pressure body bore is displaced by flow through the ports and actuates a hermetically-sealed reed switch within a separate chamber of the pressure body. As the flow decreases, the spring deactuates the switch.

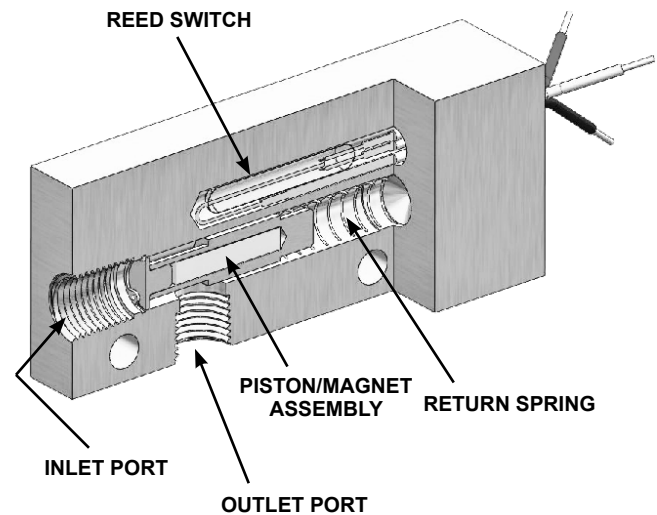

4.3 TROUBLESHOOTING

The F001 & F002 90° Angle Flow Switches are designed and manufactured for trouble-free operation over a wide range of operating conditions. Common problems are discussed in terms of their symptoms and recommended corrective actions.

4.3.1 Flow Switch Problems

SYMPTOM	PROBLEM	SOLUTION
FLOW RATE IS INACCURATE.	DIRT OR CHIPS ARE TRAPPED WITHIN THE BODY.	FLUSH OUT THE INTERIOR SURFACES. IF THE BODY IS CLOGGED WITH CONTAMINANTS, THE FLOW RATE WILL FLUCTUATE.
FLOW RATE IS INACCURATE.	THE PISTON IS STICKING.	CLEAN THE PISTON. IF CONTAMINANTS ARE CAUSING THE PISTON TO STICK, THEY MUST BE FLUSHED OUT TO PREVENT FUTURE BINDING ISSUES.

 *If you are still in doubt about the condition or performance of your control, consult the factory for further instructions.*

4.4 AGENCY APPROVALS

AGENCY	APPROVED MODEL(S)	FILE NUMBER	AREA CLASSIFICATION
UL 	F001 & F002	E203716	RECOGNIZED UNDER UL508 MOTOR CONTROLLERS (NKPZ2, NKPZ8)

4.5 SPECIFICATIONS

CAUTION! UNITS ARE CALIBRATED TO BE MOUNTED VERTICALLY WITH THE INLET FACING DOWNWARD. FOR OTHER MOUNTING ORIENTATIONS, CONSULT THE MANUFACTURER TO HAVE UNITS CALIBRATED IN THE DESIRED ORIENTATION FOR YOUR APPLICATION.

4.5.1 Functional Specifications

INPUT	
MEASUREMENT PRINCIPLE:	Spring-Loaded Piston with Internal Magnet and Reed Switch
MEASURED VARIABLE:	Flow Rate Indication Set at Customer-Specified GPM Value
OUTPUT	
SIGNAL:	Reed Switch Set Point Range
RANGE:	0.10 to 1.5 GPM
SETPOINT ACCURACY:	± 15%
SETPOINT DIFFERENTIAL:	20% Max.
TYPE OF CONTACTS:	SPST, SPDT
TYPE OF SWITCHES:	Hermetically-Sealed Reed Switch
SWITCH RATINGS:	F001: 50 VA SPST or 100 VA SPST
	F002: 20 VA SPDT or 100 VA SPDT
ELECTRICAL TERMINATION:	24" - 26", 22 AWG Polymeric Lead Wires (UL 3266)
ENVIRONMENTAL	
OPERATING TEMPERATURE:	-40° to +300° F (-40° to + 149° C)
PRESSURE RATING:	1000 PSIG (69 bar) at 100° F (37° C)
MATERIALS	
HOUSING:	Brass or 316 Stainless Steel
PISTON:	Brass or 316 Stainless Steel
SPRING:	316 Stainless Steel
RETAINING RING:	PH15-7 Mo

4.5.2 Dimensional Specifications

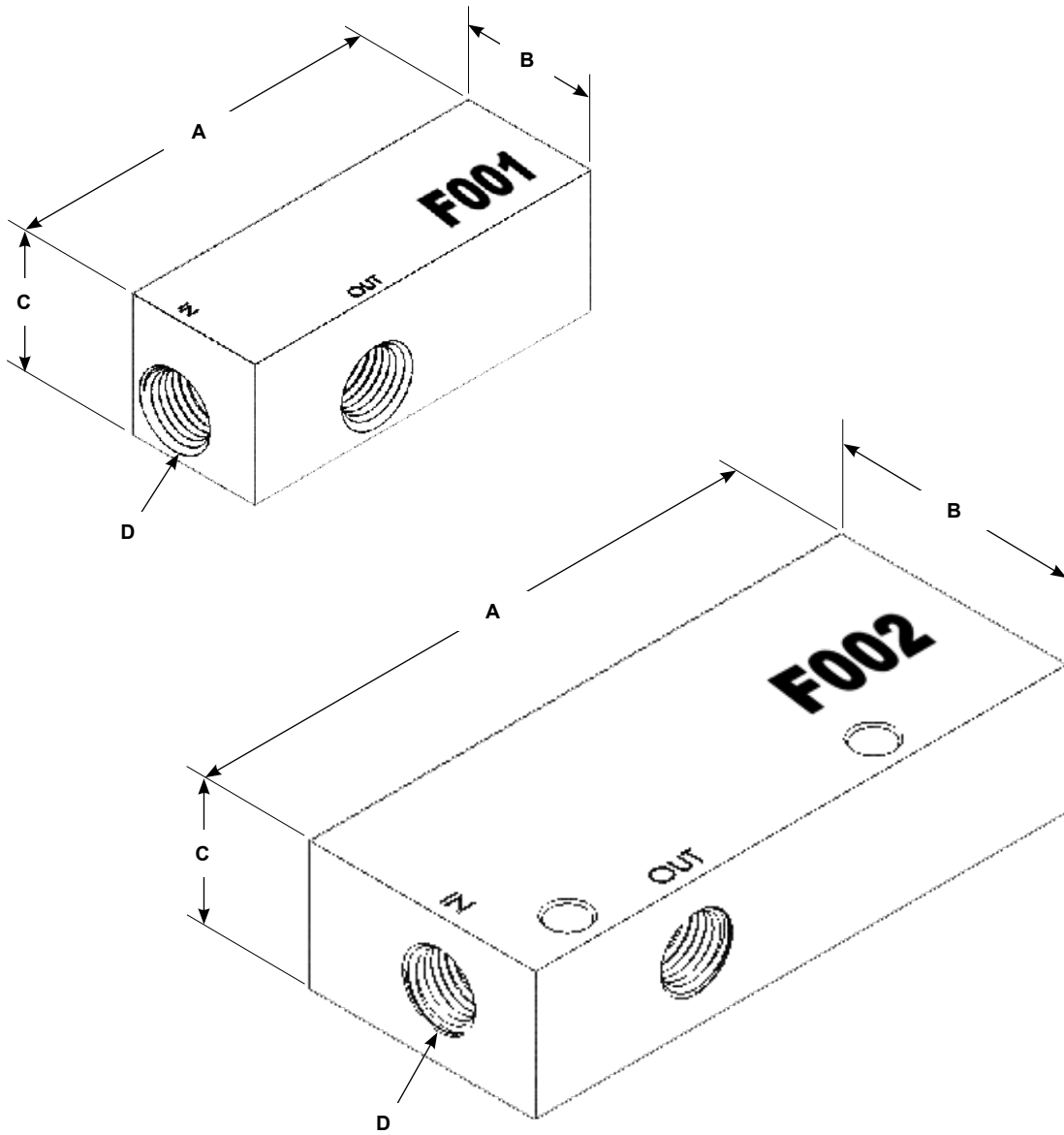

MODEL	"A" DIM.	"B" DIM.	"C" DIM.	"D" PORT SIZE NPT
F001	2 3/4"	1"	1"	1/4"
F002	4 1/8"	1 3/4"	1"	1/4"

4.6 MODEL CONFIGURATOR

TECHNOLOGY		MODEL		CONFIG.		PROCESS SIZE/MATERIAL		SWITCH		FLOW RATE*		DIRECTION	
F	Flow Switch	001	Angled, Small Body	-	Standard	XXXX	Custom Application	F001 Models		YYY	Rate (GPM)	0	Decreasing
		002	Angled, Large Body	C	Custom	0201	1/4" NPT Ports (Brass)	0	N.O. SPST (No Flow)			1	Increasing
						0208	1/4" NPT Ports (316 SS)	1	N.C. SPST (No Flow)				
								F002 Models					
								0	SPDT Std. (No Flow)				
								3	N.O. SPST (No Flow)				

F 0 0 1 - 0 2 0 1 - 2 0 1 5 - 1

***YYY = Flow Rate in Gallons Per Minute (GPM)**

Examples: 005 is 0.50 GPM
015 is 1.50 GPM

 **NOTE:** CONSULT THE MANUFACTURER FOR SPECIAL CONFIGURATIONS, MATERIALS AND MOUNTING OPTIONS.

4.7 NOTES

ASSURED QUALITY & SERVICE COST LESS

Service Policy

Owners of Solutions With Innovation products may request a return of the product, or any part of the product for complete rebuilding or replacement. Units will be rebuilt or replaced promptly. Products returned under the SWI Service Policy must be returned by prepaid transportation. Solutions With Innovation will repair or replace the product at no cost to the purchaser (or owner) other than transportation if:

- 1 Returned within the warranty period; and
- 2 Factory Inspection finds the cause of the claim to be covered under the warranty.

If the problem is due to circumstances beyond Solutions With Innovation's liability, or is NOT covered by the warranty, there will be charges for labor in addition to the parts required to rebuild or replace the equipment.

In rare cases, it may be expedient to ship replacement parts; or in extreme cases, an entire product before the damaged product is returned. If a quick replacement service is necessary, notify the manufacturer of the damaged product's model and serial number. In such cases, credit for the returned materials will be determined on the applicability of the warranty.

No claims for misapplication, labor, direct or consequential damage will be allowed.

Return Material Procedure

In order to efficiently process any returned materials, it is essential that a *Return Material Authorization* (RMA) number be obtained from the manufacturer prior to an item's return. RMA's can be issued through local representatives, or by contacting the factory directly.

Please supply the following information:

- 1 The Company's Name
- 2 Description of the Material
- 3 Product Serial Number
- 4 Reason for Return
- 5 Product's Application

Used units must be properly cleaned in accordance with OSHA standards before it is returned to the manufacturer. A *Material Safety Data Sheet* (MSDS) must accompany units or materials that were used in any type of media. All return shipments to the factory must be by done via prepaid transportation. All product replacements will be shipped F.O.B. manufacturer.



SOLUTIONS WITH INNOVATION

AN INNOVATIVE SENSING COMPANY

ISO 9001:2008 CERTIFIED

BULLETIN: IS-9310.2
EFFECTIVE: 1/15

