

L500S SUSPENDED FLOAT SWITCH

INSTALLATION AND OPERATIONS MANUAL

Single or Multi-Point, Vertically-Suspended,
Liquid Level Float Switch



SOLUTIONS WITH INNOVATION

AN INNOVATIVE SENSING COMPANY

ISO 9001:2008 CERTIFIED

This manual provides information on the **L500S Single or Multi-Point Suspended Liquid Level Float Switch**. It is important that all instructions are read carefully and followed sequentially. Detailed instructions are included in the **Complete Installation** section of this manual.

Conventions Used in this Manual

Certain conventions are used in this manual to convey specific types of information. General technical material, support data and safety information are presented in narrative form. The following styles are used for notes, cautions and warnings:

Notes

Notes contain information that augments or clarifies an operating step. Notes do not normally contain actions and often follow the procedural steps to which they refer.

Cautions

Cautions alert the technician to special conditions that could injure personnel, damage equipment, or reduce a component's mechanical integrity. Cautions are also used to alert the technician of unsafe practices, the need for special protective equipment, or specific materials. In this manual, a caution indicates a potentially hazardous situation which, if not avoided, may result in minor to moderate injury.

Notice of Copyright and Limitations

Copyright © 2015 Solutions With Innovation, LLC;
All rights reserved.

Solutions With Innovation reserves the right to make changes to the product described in this manual at any time without notice. Solutions With Innovation makes no warranty with respect to the accuracy of the information in this manual.

Warranty

All Solutions With Innovation Mechanical Level and Flow Controls are warranted free of defects in materials and workmanship for one full year from the date of the original factory shipment. If returned within the warranty period; and, upon factory inspection of the control, the cause of the claim is determined to be covered under the warranty; then, Solutions With Innovation will repair or replace the product at no cost to the purchaser (or owner) other than transportation.

Solutions With Innovation shall not be liable for misapplication, labor claims, direct or consequential damage, or expenses arising from the installation or use of the equipment. There are no other warranties expressed or implied, except special written warranties covering specific Solutions With Innovation products.

Quality Assurance

The Quality Assurance System in place at Solutions With Innovation guarantees the highest level of quality throughout the company. Solutions With Innovation is committed to providing full customer satisfaction; both in quality products and in quality service.

Contacts

Phone: 203-729-6434 *Mon-Fri, 9 AM - 5 PM EST*
Fax: 203-729-0541 *for General Inquiries*
Email: sales@innovativesensing.com

L500S SUSPENDED FLOAT SWITCH

Single or Multi-Point Liquid Level Float Switch

TABLE OF CONTENTS

1.0 Installation

1.1 Unpacking.....	4
1.2 Before You Begin.....	4
1.2.1 Site Preparation.....	4
1.2.2 Equipment and Tools.....	4
1.3 Mounting.....	5
1.3.1 Threaded Mounting.....	5
1.4 Wiring.....	5

2.0 Preventative Maintenance

2.1 What To Do.....	6
2.1.1 Inspect Entire Unit Periodically.....	6
2.1.2 Inspect Connections Monthly.....	6
2.1.3 Keep Unit Clean.....	6
2.2 What To Avoid.....	6

3.0 Reference Information

3.1 Description.....	7
3.2 Theory of Operation.....	7
3.3 Troubleshooting.....	7
3.3.1 External Causes.....	7
3.3.2 Unit Causes.....	8
3.4 Agency Approvals.....	9
3.5 Specifications.....	9
3.5.1 Physical Specifications.....	9
3.5.2 Electrical Specifications.....	9
3.5.3 Switch Wiring Codes.....	9
3.5.4 Dimensional Specifications.....	10
3.6 Model Configurator.....	10
3.7 Notes.....	11

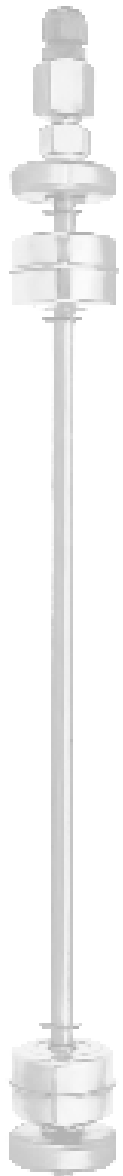

1.0 COMPLETE INSTALLATION

This section provides detailed procedures on properly installing the L500S Suspended Liquid Level Float Switch.

 **CAUTION!** IF THE EQUIPMENT IS USED IN A MANNER NOT SPECIFIED BY THE MANUFACTURER, PROTECTION PROVIDED BY THE EQUIPMENT MAY BE IMPAIRED.

 **CAUTION!** THIS UNIT CONTAINS REED SWITCHES THAT MAY BE PERMANENTLY DAMAGED BY MECHANICAL SHOCK OR VIBRATION. AVOID DROPPING OR HITTING THE DEVICE AGAINST HARD SURFACES.

1.1 UNPACKING

Unpack the instrument, carefully. Make sure that all components have been removed from the packing material. Inspect all components for damage. Report any concealed damage to the carrier within 24 hours of receiving. Compare the contents with the packing slip and report any discrepancies to the factory immediately. Record the sales order number and/or serial number for future reference when ordering parts.

Before Proceeding to Installation, Complete the Following:

- Inspect all components for damage. Report any damage to the carrier within 24 hours of receiving.
- Record the model and serial numbers for future reference when ordering parts.

Model Number _____

Serial Number _____

1.2 BEFORE YOU BEGIN

 **CAUTION!** DURING THE INSTALLATION OF THE L500S SUSPENDED LIQUID LEVEL SWITCH, THE FLOAT AREA MUST BE KEPT FREE OF METALLIC PARTICLES THAT MIGHT BE ATTRACTED TO THE FLOAT'S INTERNAL MAGNET.

1.2.1 Site Preparation

- 1 Ensure that the length and the inside diameter of the mounting is sized correctly to accommodate the L500S Suspended Liquid Level Float Switch.

1.2.2 Equipment and Tools

No special equipment or tools are required to install the L500S Suspended Liquid Level Float Switch.

The Following Are Recommended:

- Wrenches, thread sealant, gaskets and/or bolting as required for the process connection.

1.3 MOUNTING

The L500S Suspended Liquid Level Float Switch is available in a variety of threaded and flanged mountings. These devices are meant to be installed on the top of a process tank. They should be mounted in an area free of turbulence or direct streams. Contact the manufacturer for flanged mounting options.

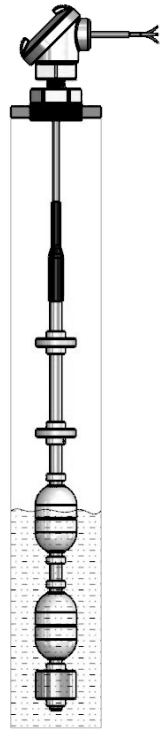

1.3.1 Threaded Mounting

How to Install an L500S Suspended Liquid Level Float Switch:

- 1 Apply either Teflon[®] tape or an appropriate thread sealant to the mounting threads to prevent galling.
- 2 Engage the thread by hand to avoid unnecessary damage.
- 3 Using a wrench, rotate the unit clockwise until the threads are tight within the mounting.
- 4 Ensure that the float(s) and stem are in a vertical orientation.

1.4 WIRING

CAUTION! OBSERVE ALL APPLICABLE ELECTRICAL CODES AND PROPER WIRING PROCEDURES.

SPST Reed Switch:

- 1 Connect the wiring to the switch leads or terminals, as illustrated below.

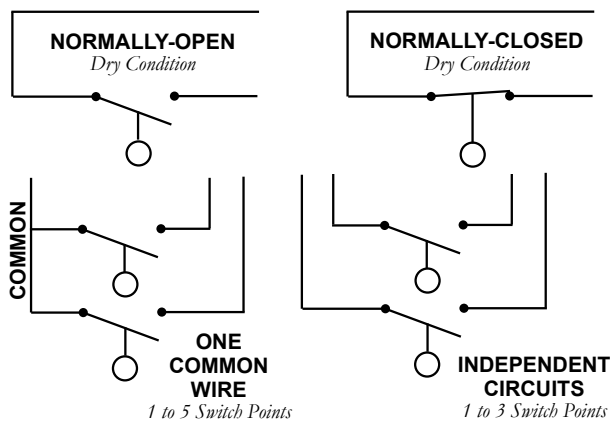

SPDT Reed Switch:

- 1 Connect the wiring to the proper switch leads or terminals, as illustrated below.

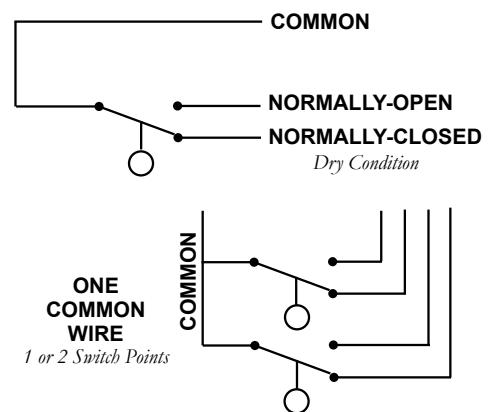

Contact Protection:

In order to maintain the life and reliability of the internal reed switch, it is essential to provide protection when switching inductive loads. When the current breaks, the energy stored in the load generates a high frequency voltage across the switch contacts. If the voltage is large enough, it can initiate arcing and cause the contacts to weld together. Damage can ultimately be prevented by suppressing the voltage. Through the use of a diode for DC circuits and a resistor-capacitor network for AC circuits, contact protection will ensure reliable performance from the reed switch.

2.0 PREVENTATIVE MAINTENANCE

Periodic inspections are necessary to maintain the proper functionality of the L500S Suspended Liquid Level Switch. The switch is a safety device that protects the equipment it serves. A systematic program of preventative maintenance should be implemented at the time of installation. If the following instructions are completed routinely, the switch will provide continuous, reliable protection.

2.1 MAINTENANCE PROCEDURES

2.1.1 Inspect Unit Periodically

Verify that there are no cracks or chipped surfaces on the unit. Should the float or stem assembly become damaged, obtain a replacement immediately.

2.1.2 Inspect Connections Monthly

L500S Suspended Liquid Level Switches may be vulnerable to excessive heat and moisture. Under these conditions, the electrical wire insulation can periodically break or peel away. As a result, the bare wires may become exposed to the elements and incur damages.

- Inspect all wiring, carefully and replace any wires exhibiting signs of brittle insulation.
- Inspect all electrical connections to ensure tightness.
- Repair or replace any wiring, if necessary.

2.1.3 Keep Unit Clean

Periodic cleanings of the float and stem assembly will ensure the continual, uninterrupted movement of the mechanism. Always keep the open area between the components clean and free of any potential interferences. Objects and debris may cause systematic interruptions and a loss in equipment functionality.

2.2 WHAT TO AVOID



NEVER LEAVE THE SWITCH WIRING EXPOSED TO THE ELEMENTS.



NEVER PLACE A JUMPER WIRE ACROSS THE TERMINALS TO “CUT-OUT” THE CONTROL. *If a jumper is necessary for testing purposes, ensure that it is removed prior to placing the control into service.*



NEVER USE IN SYSTEMS CONTAINING IRON PARTICLES. *The magnet within the float assembly can attract the particles and become jammed.*

3.0 REFERENCE INFORMATION

This section illustrates an overview of the L500S Suspended Liquid Level Switch, as well as information on troubleshooting common problems, agency approval listings, and detailed physical, functional and performance specifications.

3.1 DESCRIPTION

The L500S is a low-cost, single or multiple level switch designed for adjustable level monitoring or leak detection within storage tanks, sumps and wells. Vertically-mounted and suspended by an electrical cable to the desired switch position inside the tank, the integral weight maintains the correct orientation, as well as removes slack from the cable. A compression fitting secures the cable in place and forms a leak-tight seal. The L500S is available in PVC, brass/buna and stainless steel materials. Additional options include special configurations and switch points.

3.2 THEORY OF OPERATION

While the sensor is suspended and secured inside the tank at the intended switch level(s), the magnet within the float travels with the tank's liquid level. When the float moves up and down the stem of the sensor, its magnetic field actuates the hermetically-sealed reed switches located inside the stem tube.

3.3 TROUBLESHOOTING

The L500S Suspended Liquid Level Switch is designed and engineered for trouble-free operation over a wide range of operating conditions. Common problems are discussed in terms of their symptoms and recommended corrective actions.

3.3.1 External Causes

An initial indication of improper operation is the failure of the controlled equipment to function (pumps will not start or stop, signal lamps fail to light, etc). If these symptoms occur, whether at the time of installation or during routine service thereafter, check for potential external causes first:

- Blown Fuses
- Tripped Reset Button(s)
- Open Power Switch
- Faulty Equipment Controlled By the Level Switch
- Defective Wiring to the Level Switch

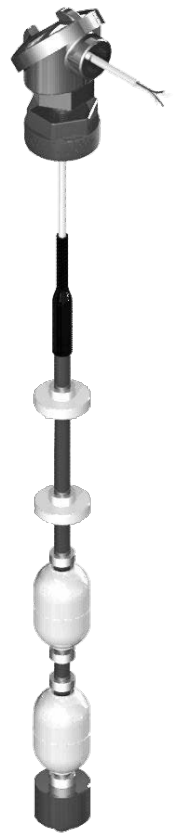

3.3.2 Unit Causes

If a thorough inspection of any external causes fails to locate the problem, proceed to an inspection of the unit, itself. **DISCONNECT POWER TO THE LEVEL SWITCH BEFORE PROCEEDING.**

SYMPTOM	PROBLEM	SOLUTION
THE UNIT IS UNRESPONSIVE.	ELECTRICAL FAILURE.	USE AN ELECTRICAL CONTINUITY CHECKER TO DETERMINE IF THE SWITCH IS FUNCTIONAL. IF THE SWITCH DOES NOT OPERATE PROPERLY WHEN ACTIVATED, THE ENTIRE LEVEL SWITCH MUST BE REPLACED.
THE UNIT DOES NOT ACTIVATE WHEN THE FLOAT CHANGES POSITION.	THE UNIT IS JAMMED.	REMOVE THE LEVEL SWITCH FROM SERVICE. CHECK THE FLOAT ASSEMBLY FOR OBSTRUCTIONS OR ACCUMULATION OF PARTICLES WHICH MAY CAUSE BINDING. IF BINDING IS PRESENT IN THE FLOAT ASSEMBLY AND CANNOT BE CLEARED BY NORMAL CLEANING PROCEDURES, THE ENTIRE CONTROL MUST BE REPLACED.
THE UNIT ONLY FUNCTIONS WHEN IT IS NOT IN SERVICE.	LIQUID IS NOT ENTERING THE VESSEL.	CHECK TO ENSURE THAT LIQUID IS ENTERING THE TANK OR VESSEL. A CLOSED VALVE OR CLOGGED PIPELINE MAY PREVENT MOVEMENT OF THE LIQUID IN THE VESSEL.
THE UNIT ONLY FUNCTIONS WHEN IT IS NOT IN SERVICE.	THE TANK LEVEL IS NOT HIGH ENOUGH TO HAVE THE FLOAT FUNCTION.	CHECK THE FLOAT TO MAKE SURE IT IS BUOYANT IN THE LIQUID. THE TANK OR VESSEL MUST HAVE AN ADEQUATE LIQUID LEVEL.
THE FLOAT IS NOT BUOYANT.	THE FLOAT IS COLLAPSED AND/OR FILLED WITH LIQUID.	CHECK THE FLOAT FOR RUPTURES, DEFORMATION, AND ANY LIQUID TRAPPED INSIDE THE ASSEMBLY. IF THE FLOAT IS FILLED WITH LIQUID OR HAS COLLAPSED, THE ENTIRE LEVEL SWITCH MUST BE REPLACED. DO NOT ATTEMPT TO REPAIR THE FLOAT.
ALL COMPONENTS WITHIN THE LEVEL SWITCH ARE IN WORKING ORDER, BUT THE UNIT STILL DOES NOT FUNCTION.	AN EXTERNAL PROBLEM.	REPEAT AN INSPECTION OF THE EXTERNAL CONDITIONS AS DESCRIBED IN SECTION 3.3.1.

 *If you are still in doubt about the condition or performance of your control, consult the factory for further instructions.*

3.4 AGENCY APPROVALS

AGENCY	APPROVED MODEL(S)	FILE NUMBER	AREA CLASSIFICATION
UL 	L500	E203716	RECOGNIZED UNDER UL508 MOTOR CONTROLLERS & NJ0T8 MOTOR CONTROLLERS

3.5 SPECIFICATIONS

3.5.1 Physical Specifications

FLOAT MATERIAL	DIMENSIONS	TEMPERATURE	PRESSURE	MIN. SPECIFIC GRAVITY
PVC	1" x 1"	-40° to +140° F	50 PSIG	1.00
316 Stainless Steel	1.50" x 1.30"	-40° to +300° F	120 PSIG	0.80
316 Stainless Steel	2" Ball	-40° to +300° F	750 PSIG	0.79
316 Stainless Steel	1.85" x 3"	-40° to +300° F	400 PSIG	0.76
Buna-N	1.875" x 1.75"	-40° to +180° F	150 PSIG	0.65

3.5.2 Electrical Specifications

SIGNAL OUTPUT	Switch Closure
TYPE OF CONTACTS	SPST, SPDT
TYPE OF SWITCHES	Hermetically-Sealed Reed Switch
SWITCH RATING	20 VA, 240 VAC/VDC Max. SPST
	50 VA, 240 VAC/VDC Max. SPST
	100 VA, 240 VAC/VDC Max. SPST
	100 VA, 240 VAC/VDC Max. SPDT

3.5.3 Switch Wiring Codes

WIRING OPTIONS	GROUP 1	GROUP 2	
	SPST	SPST	SPST
Common Wire	Black	None	
(Levels)	N.O. or N.C.	N.O.	N.C.
L1	Red	Red	Black
L2	White	Green	White
L3	Green	Brown	Blue
L4	Orange	Orange	Yellow

- 1 All SPST switches are set to normally-open operation in their "dry", "no level" condition unless specified otherwise.
- 2 Each switching point requires one float. For special applications, a single float can be used to activate two switch points, though these points must have a minimum separation of 1/8" (3 mm). The maximum number of actuation levels depends on the wiring type selected.
- 3 Standard Cables are 15' long, 22 AWG, UL 2464 cable.

3.5.4 Dimensional Specifications

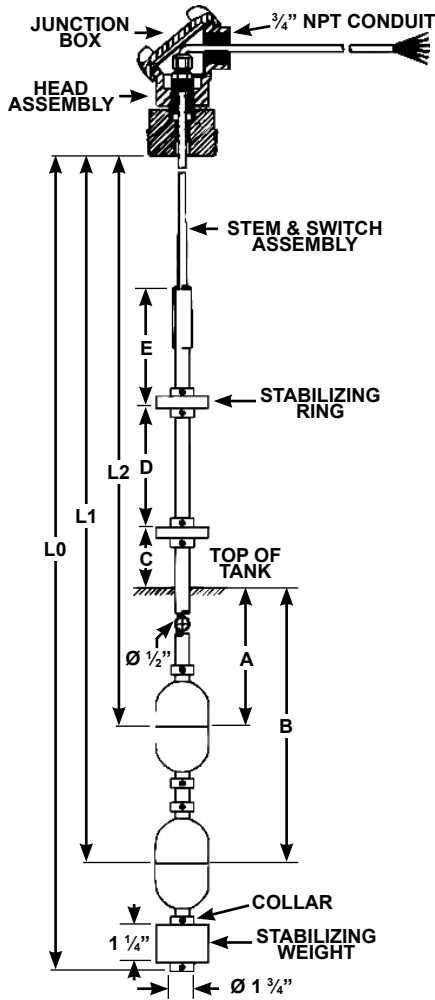

Area Definitions

DEFINITION	
A	Distance To Top of Tank From Highest Level
B	Distance To Top of Tank From Lowest Level
C	Distance From Top of Tank To Bottom Stabilizing Ring
D	Distance From Top of Tank To Top Stabilizing Ring
E	Distance From Top Stabilizing Ring To Top of Stem Assembly

Notes

- 1 A, B, L1 and L2 dimensions are based on a specific gravity of 1.0.
- 2 When using one float for two actuation points, contact the factory for the available switch ratings.
- 3 Actuation levels are calibrated on descending fluid levels with water as the fluid, unless otherwise specified.
- 4 Standard tolerance on actuation levels is $\pm 1/8"$ (3 mm).

3.6 MODEL CONFIGURATOR

TECHNOLOGY	MODEL	CONFIG.	MOUNT	STEM	FLOAT	ELECTRICAL	ENCLOSURE								
L	Liquid Level Sensor	500	1/2" Stem	S	Suspended	00	No Mount	01	Brass	05	PVC (Hollow)	03	50 VA SPST	0	No Enclosure
						08	1 1/2" NPT	05	PVC	08	316 S.S.	04	100 VA SPST	1	Polypropylene NEMA 4
						09	2" NPT	08	316 S.S.	20	Buna-N	08	100 VA SPDT	2	Aluminum NEMA 4/7/9
												14	20 VA SPST	3	Cast Iron NEMA 4/7/9

L	5	0	0	5	0	8	0	1	-	2	0	0	3	-	2
---	---	---	---	---	---	---	---	---	---	---	---	---	---	---	---

3.7 NOTES

ASSURED QUALITY & SERVICE COST LESS

Service Policy

Owners of Solutions With Innovation products may request a return of the product, or any part of the product for complete rebuilding or replacement. Units will be rebuilt or replaced promptly. Products returned under the SWI Service Policy must be returned by prepaid transportation. Solutions With Innovation will repair or replace the product at no cost to the purchaser (or owner) other than transportation if:

- 1 Returned within the warranty period; and
- 2 Factory Inspection finds the cause of the claim to be covered under the warranty.

If the problem is due to circumstances beyond Solutions With Innovation's liability, or is NOT covered by the warranty, there will be charges for labor in addition to the parts required to rebuild or replace the equipment.

In rare cases, it may be expedient to ship replacement parts; or in extreme cases, an entire product before the damaged product is returned. If a quick replacement service is necessary, notify the manufacturer of the damaged product's model and serial number. In such cases, credit for the returned materials will be determined on the applicability of the warranty.

No claims for misapplication, labor, direct or consequential damage will be allowed.

Return Material Procedure

In order to efficiently process any returned materials, it is essential that a *Return Material Authorization* (RMA) number be obtained from the manufacturer prior to an item's return. RMA's can be issued through local representatives, or by contacting the factory directly.

Please supply the following information:

- 1 The Company's Name
- 2 Description of the Material
- 3 Product Serial Number
- 4 Reason for Return
- 5 Product's Application

Used units must be properly cleaned in accordance with OSHA standards before it is returned to the manufacturer. A *Material Safety Data Sheet* (MSDS) must accompany units or materials that were used in any type of media. All return shipments to the factory must be by done via prepaid transportation. All product replacements will be shipped F.O.B. manufacturer.



SOLUTIONS WITH INNOVATION

AN INNOVATIVE SENSING COMPANY

ISO 9001:2008 CERTIFIED

BULLETIN: IS-9192.2
EFFECTIVE: 1/15

