

# L072 LIQUID LEVEL FLOAT SWITCH

## INSTALLATION AND OPERATIONS MANUAL

Side-Mounted Liquid Level Float Switch With Manual Reset  
*For Industrial Use*

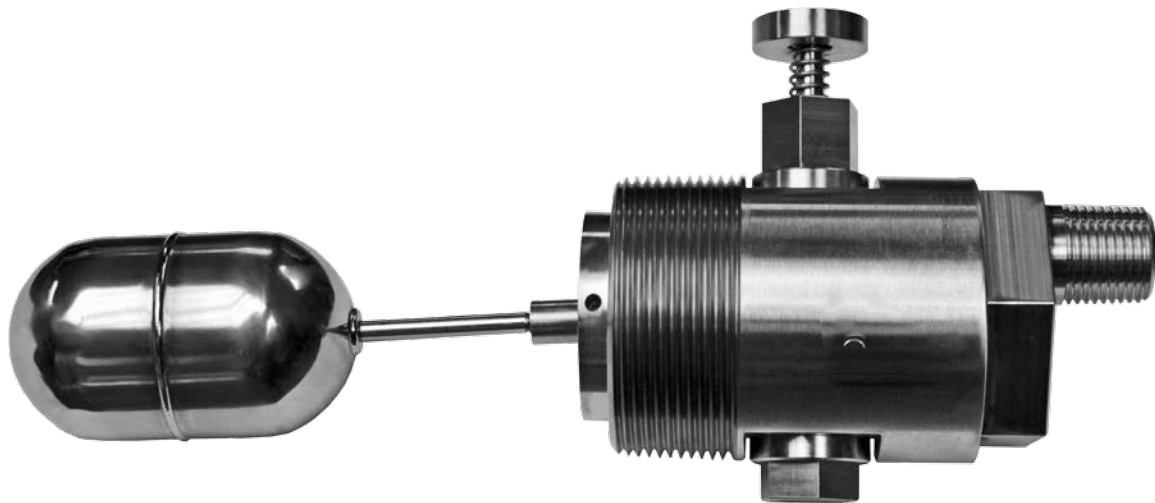

**SOLUTIONS WITH INNOVATION**

AN INNOVATIVE SENSING COMPANY

ISO 9001:2008 CERTIFIED



## READ THIS MANUAL PRIOR TO INSTALLATION

This manual provides information on the **L072 Side-Mounted Liquid Level Float Switch with Manual Reset**. It is important that all instructions are read carefully and followed sequentially. Detailed instructions are included in the **Complete Installation** section of this manual.

### Conventions Used in this Manual

Certain conventions are used in this manual to convey specific types of information. General technical material, support data and safety information are presented in narrative form. The following styles are used for notes, cautions and warnings:

#### Notes

Notes contain information that augment or clarify an operating step. Notes do not normally contain actions and often follow the procedural steps to which they refer.

#### Cautions

Cautions alert the technician to special conditions that could injure personnel, damage equipment, or reduce a component's mechanical integrity. Cautions are also used to alert the technician of unsafe practices, the need for special protective equipment, or specific materials. In this manual, a caution indicates a potentially hazardous situation which, if not avoided, may result in minor to moderate injury.

#### Warnings

Warnings identify potentially dangerous situations, or serious hazards. In this manual, a warning indicates an imminently hazardous situation which, if not avoided, may result in serious injury or death.

### Safety Messages

Follow all standard industry procedures for servicing electrical and computer equipment when working with, or around high voltage. Always shut off the power supply before touching any components.

#### WARNING!

**EXPLOSION HAZARD. DO NOT CONNECT OR DISCONNECT THE EQUIPMENT UNLESS THE POWER HAS BEEN SWITCHED OFF.**

#### ATTENTION!

**RISQUE D'EXPLOSION. NE PAS BRANCHER OU DÉBRANCHER L'APPAREIL, SAUF L'ALIMENTATION A ÉTÉ COUPÉE.**

### Low Voltage Directive

*For use in Installation Category II, Pollution Degree 2.*  
If the equipment is used in a manner not specified by the manufacturer, protection provided by equipment may be impaired.

### Notice of Copyright and Limitations

Copyright © 2016 Solutions With Innovation, LLC;  
*All rights reserved.*

Solutions With Innovation reserves the right to make changes to the product described in this manual at any time without notice. Solutions With Innovation makes no warranty with respect to the accuracy of the information in this manual.

### Warranty

All Solutions With Innovation Mechanical Level and Flow Controls are warranted free of defects in materials and workmanship for one full year from the date of the original factory shipment. If returned within the warranty period; and, upon factory inspection of the control, the cause of the claim is determined to be covered under the warranty; then, Solutions With Innovation will repair or replace the product at no cost to the purchaser (or owner) other than transportation.

Solutions With Innovation shall not be liable for misapplication, labor claims, direct or consequential damage, or expenses arising from the installation or use of the equipment. There are no other warranties expressed or implied, except special written warranties covering specific Solutions With Innovation products.

### Quality Assurance

The Quality Assurance System in place at Solutions With Innovation guarantees the highest level of quality throughout the company. Solutions With Innovation is committed to providing full customer satisfaction; both in quality products and in quality service.

### Contacts

Phone: 203-729-6434 *Mon-Fri, 9 AM - 5 PM EST*  
Fax: 203-729-0541 *for General Inquiries*  
Email: sales@innovativesensing.com

# L072 LIQUID LEVEL FLOAT SWITCH

*With Manual Reset For Industrial Use*

## TABLE OF CONTENTS

### 1.0 Installation

1.1 Unpacking.....	4
1.2 Before You Begin.....	4
1.2.1 Site Preparation.....	4
1.2.2 Equipment and Tools.....	4
1.3 Mounting.....	5
1.3.1 Threaded Mounting.....	5
1.3.2 Flanged Mounting.....	5
1.4 Installation of Actuator Assembly.....	5
1.4.1 Normally-Closed Operation.....	5
1.4.2 Normally-Open Operation.....	5
1.5 Wiring.....	6

### 2.0 Preventative Maintenance

2.1 What To Do.....	6
2.1.1 Inspect Entire Unit Periodically.....	6
2.1.2 Inspect Connections Monthly.....	7
2.1.3 Keep Unit Clean.....	7
2.2 What To Avoid.....	7

### 3.0 Reference Information

3.1 Description.....	8
3.2 Theory of Operation.....	8
3.3 Troubleshooting.....	8
3.3.1 External Causes.....	8
3.3.2 Unit Causes.....	9
3.4 Agency Approvals.....	10
3.5 Specifications.....	10
3.5.1 Functional Specifications.....	10
3.5.2 Enclosure Specifications.....	11
3.5.3 Dimensional Specifications.....	11
3.6 Model Configurator.....	12
3.7 Notes.....	13

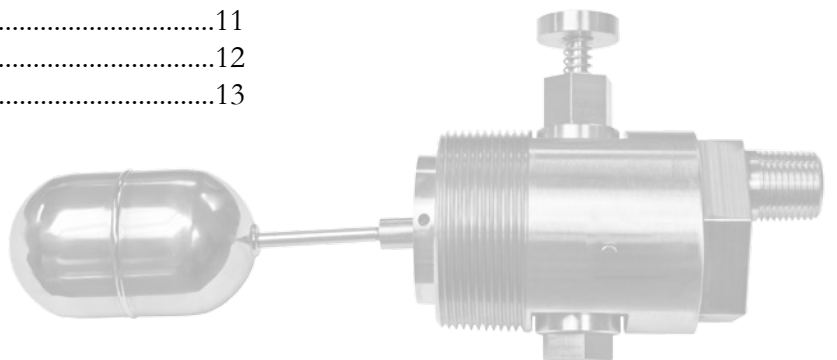

## 1.0 COMPLETE INSTALLATION

This section provides detailed procedures on properly installing the L072 Side-Mounted Liquid Level Float Switch with Manual Reset.

 **CAUTION!** IF THE EQUIPMENT IS USED IN A MANNER NOT SPECIFIED BY THE MANUFACTURER, PROTECTION PROVIDED BY THE EQUIPMENT MAY BE IMPAIRED.

### 1.1 UNPACKING

Unpack the instrument, carefully. Make sure that all components have been removed from the packing material. Inspect all components for damage. Report any concealed damage to the carrier within 24 hours of receiving. Compare the contents with the packing slip and report any discrepancies to the factory immediately. Record the sales order number and/or the serial number for future reference when ordering parts.

#### **Before Proceeding to Installation, Complete the Following:**

- Inspect all components for damage. Report any damage to the carrier within 24 hours of receiving.
- Record the model and serial numbers for future reference when ordering parts.

Model Number \_\_\_\_\_

Serial Number \_\_\_\_\_

### 1.2 BEFORE YOU BEGIN

 **CAUTION!** DURING THE INSTALLATION OF THE L072, THE FLOAT AND PIVOT AREA MUST BE KEPT FREE OF METALLIC PARTICLES THAT MIGHT BE ATTRACTED TO THE FLOAT'S INTERNAL MAGNET.

 **CAUTION!** THIS INSTRUMENT IS INTENDED FOR USE IN INSTALLATION CATEGORY II, POLLUTION DEGREE 2.

#### 1.2.1 Site Preparation

- 1 Ensure that the length and the inside diameter of the mounting nozzle is sized correctly to accommodate the L072. Refer to **Section 3.5.3** for spacial requirements.
- 2 Verify that the mounting nozzle, coupling or flange is within 3° of the horizon. If the L072 is mounted in an external cage, ensure that the top/bottom piping is within 3° of vertical in all directions.

#### 1.2.2 Equipment and Tools

No special equipment or tools are required to install the L072 Side-Mounted Liquid Level Float Switch.

#### **The Following Are Recommended:**

- Wrenches, thread sealant, gaskets and/or bolting as required for the process connection.
- Level
- Pipe Wrench

---

## **1.3 MOUNTING**

The L072 Side-Mounted Liquid Level Float Switch with Manual Reset is available in a 1 ½” or 2” threaded mount bushing as well as several flange mounting options.

### **1.3.1 Threaded Mounting**

- 1 Apply either Teflon<sup>®</sup> tape or an appropriate thread sealant to the mounting threads to prevent galling.
- 2 Engage the thread by hand to avoid unnecessary damage.
- 3 Using a pipe wrench, rotate the unit clockwise until the threads are tight within the mounting.
- 4 Ensure that the N.O. marking on the body is orientated upward for normally-open operation on SPST switch models. For normally-closed operation, ensure that the N.C. marking is orientated upward. Models with SPDT or DPDT switches should be mounted with the N.O. marking orientated upward.

### **1.3.2 Flanged Mounting**

- 1 Have proper flange bolting and gasket(s) on hand.
- 2 Carefully align the bolt holes of the L072 flange with those of the vessel mounting flange.
- 3 Ensure that the N.O. marking on the body is orientated upward for normally-open operation on SPST switch models. For normally-closed operation, ensure that the N.C. marking is orientated upward. Models with SPDT or DPDT switches should be mounted with the N.O. marking orientated upward.
- 4 Verify that the flange gasket is seated properly. Then, install and torque the flange bolts.

## **1.4 INSTALLATION OF ACTUATOR ASSEMBLY**

### **1.4.1 Normally-Closed Operation**

- 1 Orient the L072 Side-Mounted Liquid Level Float Switch with the “NC” marking on top in the vessel.
- 2 Install the Actuator Assembly into the side with the “NC” marking and tighten.
- 3 Insert the port plug into the opposite side with the “NO” marking and tighten.
- 4 Test the operation by pushing the actuator and confirming the opening of the circuit.

### **1.4.2 Normally-Open Operation**

- 1 Orient the L072 Side-Mounted Liquid Level Float Switch with the “NO” marking on top in the vessel.
- 2 Install the Actuator Assembly into the side with the “NO” marking and tighten.
- 3 Insert the port plug into the opposite side with the “NC” marking and tighten.
- 4 Test the operation by pushing the actuator and confirming the closing of the circuit.

## 1.5 WIRING

**CAUTION!** OBSERVE ALL APPLICABLE ELECTRICAL CODES AND PROPER WIRING PROCEDURES.

**NOTE:** A SWITCH OR CIRCUIT BREAKER SHOULD BE INSTALLED IN CLOSE PROXIMITY TO THE EQUIPMENT AND WITHIN EASY ACCESS OF THE OPERATOR. MARK THE UNIT AS THE DISCONNECTING DEVICE FOR THE EQUIPMENT.

**NOTE:** FOR SUPPLY CONNECTIONS IN INSTALLATIONS WITH AN AMBIENT TEMPERATURE UP TO +70° C, USE WIRE WITH A MINIMUM RATING OF 75° C AS REQUIRED BY THE PROCESS CONDITIONS. FOR SUPPLY CONNECTIONS IN INSTALLATIONS WITH AN AMBIENT TEMPERATURE UP TO +80° C, USE WIRE WITH A MINIMUM RATING OF 85° C AS REQUIRED BY THE PROCESS CONDITIONS. USE A MINIMUM OF 14 AWG WIRE FOR POWER AND GROUND FIELD WIRES.

### SPST Reed Switch:

- 1 Connect the wiring to the red switch leads or terminals, as illustrated to the right.

SPST WIRING DIAGRAM

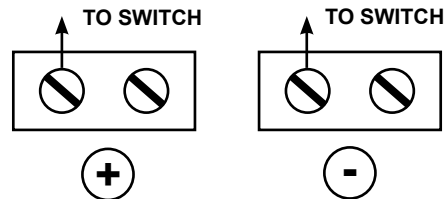

### SPDT Reed Switch:

- 1 Connect the wiring to the proper switch leads or terminals, as illustrated to the right and below.

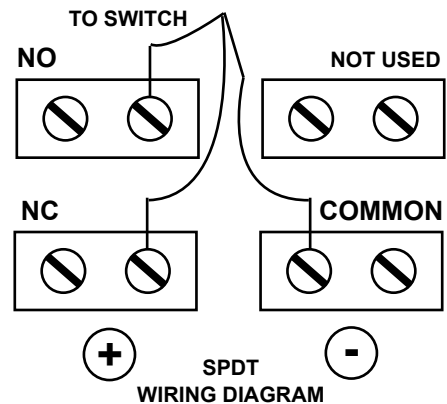
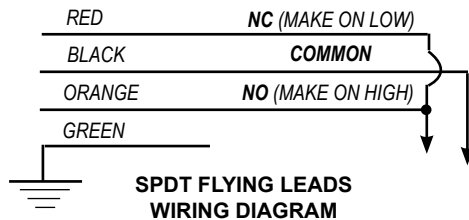

### DPDT Relay:

- 1 Connect the wiring to the proper terminals by color and run the power supply, as illustrated to the right.
- 2 This relay must be powered to function. 5 Amps at 24 VDC relays require a 24 VDC power supply. 5 Amps at 120 VAC relays require a 120 VAC power supply.

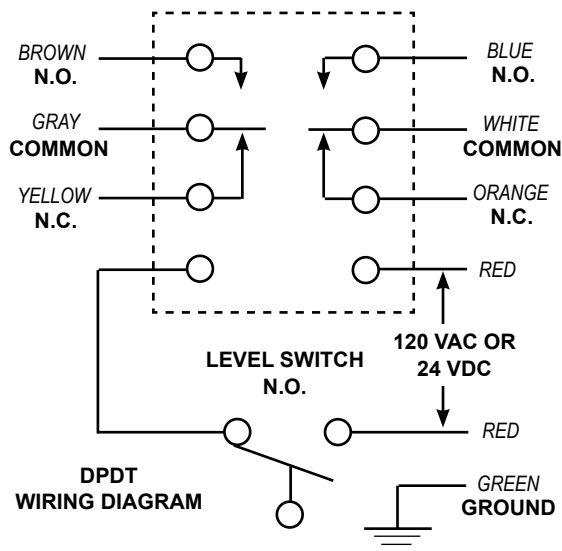

---

## 2.0 PREVENTATIVE MAINTENANCE

Periodic inspections are necessary to maintain the proper functionality of the L072 Side-Mounted Liquid Level Switch for Industrial Use. The switch is a safety device that protects the equipment it serves. A systematic program of preventative maintenance should be implemented at the time of installation. If the following instructions are completed routinely, the switch will provide continuous, reliable protection.

### 2.1 MAINTENANCE PROCEDURES

#### 2.1.1 Inspect Unit Periodically

Verify that there are no cracks or chipped surfaces on the switch's housing. Should the enclosure become damaged, obtain a replacement immediately.

#### 2.1.2 Inspect Connections Monthly

L072 Side-Mounted Liquid Level Switches may be vulnerable to excessive heat and moisture. Under these conditions, the electrical wire insulation can periodically break or peel away. As a result, the bare wires may become exposed to the elements and incur damages.

- Inspect all wiring, carefully and replace any wires exhibiting signs of brittle insulation.
- Inspect all electrical connections to ensure tightness.
- Repair or replace any wiring, if necessary.

#### 2.1.3 Keep Unit Clean

Periodic cleaning of the float, pivot and magnet assembly will ensure the continual, uninterrupted movement of the mechanism. Objects and debris may cause systematic interruptions and a loss in equipment functionality.

 **CAUTION!** OPEN THE CIRCUIT BEFORE REMOVING THE COVER.  
**ATTENTION!** OUVRIRE LE CIRCUIT AVANT DE RETIRER LE COUVERCLE.

 **CAUTION!** THE COVER THREADS MUST BE CLEANED BEFORE REPLACING THE COVER.  
**ATTENTION!** LES JOINTS DE COUVERTURE DOIVENT ÊTRE NETTOYÉS AVANT DE REMETTRE LE COUVERCLE.

 **CAUTION!** A SEAL SHOULD BE INSTALLED WITHIN 18 INCHES OF THE ENCLOSURE.  
**ATTENTION!** UN JOINT DOIT ÊTRE INSTALLÉ MOINS DE 450 MILLIMÈTRES DU CAS.

### 2.2 WHAT TO AVOID

 **NEVER LEAVE THE SWITCH HOUSING COVER OFF OF THE SENSOR.** *Exposed wires can incur damage. When performing routine maintenance, remove the housing as necessary to inspect the sensor.*

 **NEVER PLACE A JUMPER WIRE ACROSS THE TERMINALS TO "CUT-OUT" THE CONTROL.** *If a jumper is necessary for testing purposes, ensure that it is removed prior to placing the control into service.*

 **NEVER USE IN SYSTEMS CONTAINING IRON PARTICLES.** *The magnet within the float assembly can attract the particles and become jammed.*

 **NEVER PUT INSULATION OVER THE SWITCH HOUSING.**

## 3.0 REFERENCE INFORMATION

This section illustrates an overview of the L072 Side-Mounted Liquid Level Switch for Industrial Use, as well as information on troubleshooting common problems, agency approval listings, and detailed physical, functional and performance specifications.

### 3.1 DESCRIPTION

The L072 Side-Mounted Liquid Level Switch for Industrial Use is a float-actuated device designed to be horizontally mounted within a process vessel through threaded or flanged connections. The low-cost switch is ideal for OEM applications where a single-point high or low level alarm is desired.

### 3.2 THEORY OF OPERATION

The switching action is achieved through the use of an internal magnet within the float assembly and its interaction with the switch mechanism. As the liquid level fluctuates inside the tank, the float travels. Its magnetic field actuates the switch inside the stem and completes an electrical circuit.

The manual override button physically moves the float rod to close or open the switch. This assembly may be relocated to either N.O. normally-open or N.C. normally-closed positions on the housing.

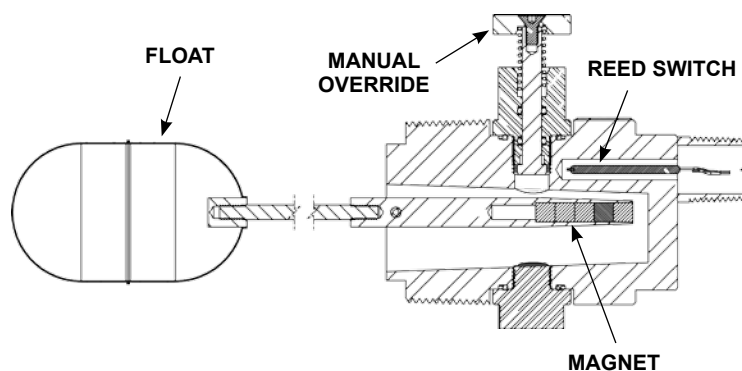

### 3.3 TROUBLESHOOTING

The L072 Side-Mounted Liquid Level Switch for Industrial Use is designed and manufactured for trouble-free operation over a wide range of operating conditions. Common problems are discussed in terms of their symptoms and recommended corrective actions.

#### 3.3.1 External Causes

An initial indication of improper operation is the failure of the controlled equipment to function (pumps will not start or stop, signal lamps fail to light, etc). If these symptoms occur, whether at the time of installation or during routine service thereafter, check for potential external causes first:

- Blown Fuses
- Tripped Reset Button(s)
- Open Power Switch
- Faulty Equipment Controlled By the Level Switch
- Defective Wiring to the Level Switch





### 3.3.2 Unit Causes

If a thorough inspection of any external causes fails to locate the problem, proceed to an inspection of the unit, itself. **DISCONNECT POWER TO THE LEVEL SWITCH BEFORE PROCEEDING.**

SYMPTOM	PROBLEM	SOLUTION
THE UNIT IS UNRESPONSIVE.	ELECTRICAL FAILURE.	USE AN ELECTRICAL CONTINUITY CHECKER TO DETERMINE IF THE SWITCH IS CHANGING STATE. IF THE SWITCH DOES NOT OPERATE PROPERLY WHEN ACTIVATED, THE ENTIRE LEVEL SWITCH MUST BE REPLACED.
THE UNIT IS UNRESPONSIVE. (DPDT)	THE UNIT IS IMPROPERLY POWERED.	UNITS WITH A DPDT RELAY MUST BE PROPERLY POWERED (24 VDC OR 120 VAC) IN ORDER TO WORK. THE RELAY WILL NOT FUNCTION UNLESS THE UNIT IS POWERED.
THE UNIT DOES NOT ACTIVATE WHEN THE FLOAT CHANGES POSITION.	THE UNIT IS JAMMED.	REMOVE THE LEVEL SWITCH FROM SERVICE. CHECK THE FLOAT ASSEMBLY FOR OBSTRUCTIONS OR ACCUMULATION OF PARTICLES WHICH MAY CAUSE BINDING. IF BINDING IS PRESENT IN THE FLOAT ASSEMBLY AND CANNOT BE CLEARED BY NORMAL CLEANING PROCEDURES, THE ENTIRE CONTROL MUST BE REPLACED.
THE UNIT ONLY FUNCTIONS WHEN IT IS NOT IN SERVICE.	LIQUID IS NOT ENTERING THE VESSEL.	CHECK TO ENSURE THAT LIQUID IS ENTERING THE TANK OR VESSEL. A CLOSED VALVE OR CLOGGED PIPELINE MAY PREVENT MOVEMENT OF THE LIQUID IN THE VESSEL.
THE UNIT ONLY FUNCTIONS WHEN IT IS NOT IN SERVICE.	THE TANK LEVEL IS NOT HIGH ENOUGH TO HAVE THE FLOAT FUNCTION.	CHECK THE FLOAT TO MAKE SURE IT IS BUOYANT IN THE LIQUID. THE TANK OR VESSEL MUST HAVE AN ADEQUATE LIQUID LEVEL.
THE FLOAT IS NOT BUOYANT.	THE FLOAT IS COLLAPSED AND/OR FILLED WITH LIQUID.	CHECK THE FLOAT FOR RUPTURES, DEFORMATION, AND ANY LIQUID TRAPPED INSIDE THE ASSEMBLY. IF THE FLOAT IS FILLED WITH LIQUID OR HAS COLLAPSED, THE ENTIRE LEVEL SWITCH MUST BE REPLACED. <b>DO NOT ATTEMPT TO REPAIR THE FLOAT.</b>
ALL COMPONENTS WITHIN THE LEVEL SWITCH ARE IN WORKING ORDER, BUT THE UNIT STILL DOES NOT FUNCTION.	THE PROBLEM IS EXTERNAL TO THE SWITCH.	REPEAT AN INSPECTION OF THE EXTERNAL CONDITIONS AS DESCRIBED IN <b>SECTION 3.3.1.</b>

 *If you are still in doubt about the condition or performance of your sensor, consult the factory for further instructions.*

### 3.4 AGENCY APPROVALS

AGENCY	APPROVED MODEL(S)	FILE NUMBER	PROTECTION	AREA CLASSIFICATION
UL 	L072	E203716	EXPLOSION-PROOF	RECOGNIZED UNDER UL508 MOTOR CONTROLLERS
FM 	L072-BBCC-DDEE L072ABBCC-DDEE	3009422 3024568 3059549	EXPLOSION-PROOF	<b>WITH ENCLOSURE:</b> CLASS I, DIV 1; GROUPS C & D CLASS II, DIV 1; GROUPS E, F & G CLASS III, TYPE 4, T6 <b>NO ENCLOSURE:</b> CLASS I, DIV 1; GROUPS A, B, C & D
CSA 	L072-BBCC-DDEE L072ABBCC-DDEE	212679	EXPLOSION-PROOF	<b>WITH ENCLOSURE:</b> CLASS I, DIV 1; GROUPS C & D CLASS II, DIV 1; GROUPS E, F & G CLASS III, TYPE 4, T6 <b>NO ENCLOSURE:</b> CLASS I, DIV 1; GROUPS A, B, C & D

### 3.5 SPECIFICATIONS

#### 3.5.1 Functional Specifications

INPUT	
MEASURED VARIABLE:	Liquid Level
OUTPUT	
SIGNAL:	Switch Closure
PHYSICAL RANGE:	Narrow Differential, 0.50"
TYPE OF CONTACTS:	SPST, SPDT or DPDT
TYPE OF SWITCHES:	Hermetically-Sealed Reed Switch
SWITCH RATINGS:	SPST 100 VA, 240 Volts Max SPDT 30 VA, 240 Volts Max DPDT 24 VDC, 240 Volts Max DPDT 120 VAC, 240 Volts Max
ELECTRICAL CONNECTION:	½" NPT or Conduit Box(es) with ¾" NPT
ENVIRONMENTAL	
PROCESS TEMPERATURE:	-40° to +300° F (-40° to +149° C)
AMBIENT TEMPERATURE:	-40° to +160° F (-40° to +71° C)
MAXIMUM PROCESS PRESSURE:	1 ½" & 2" NPT (Stainless Steel Float): 1,000 PSIG 2", 2 ½", 3" & 4" #150 ANSI Flange: 175 PSIG 2", 2 ½", 3" & 4" #300 ANSI Flange: 455 PSIG
MINIMUM SPECIFIC GRAVITY:	0.40
MATERIALS	
FLOAT:	316/316L Stainless Steel, Titanium, Hastelloy C-276
MOUNTING CONNECTION:	316/316L Stainless Steel, Hastelloy C-276
TRIM:	316/316L Stainless Steel with 18-8 Stainless Pivot Pin
HOUSING MOUNTING:	Provisions for (4) #10 Screws
PROCESS CONNECTION:	1 ½" NPT, 2" NPT, or BSP Threads 2", 2 ½", 3" or 4" (#150 or #300 ANSI Flanges)

### 3.5.2 Enclosure Specifications

<b>ENCLOSURE RATING</b>	NEMA 4 (OZ Gedney); NEMA 4, 7, 9 (Pyromation); NEMA 4X IP66 (Moore) Class I, Div. 1, Groups C & D
<b>ENCLOSURE MATERIAL</b>	316/316L Stainless Steel, Cast Iron/Aluminum, or Aluminum

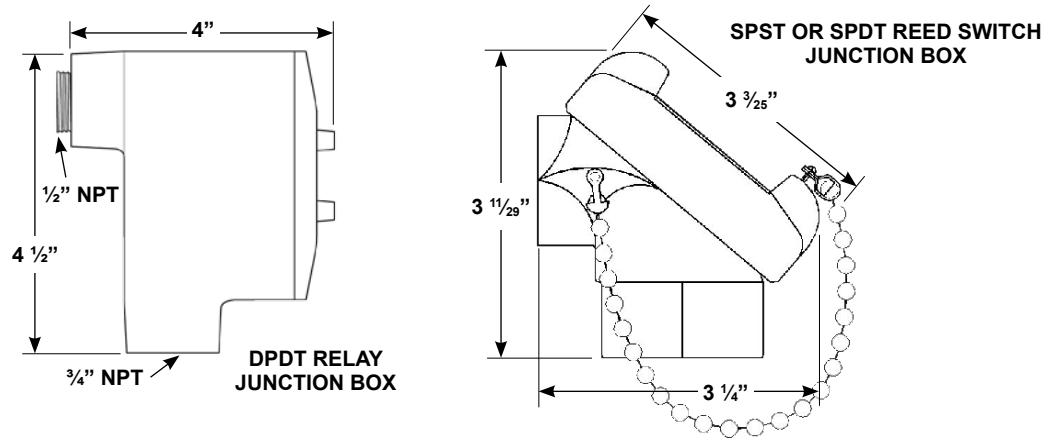

### 3.5.3 Dimensional Specifications

L072 WITH THREADED CONNECTION & SPST or SPDT Switch with Flying Leads

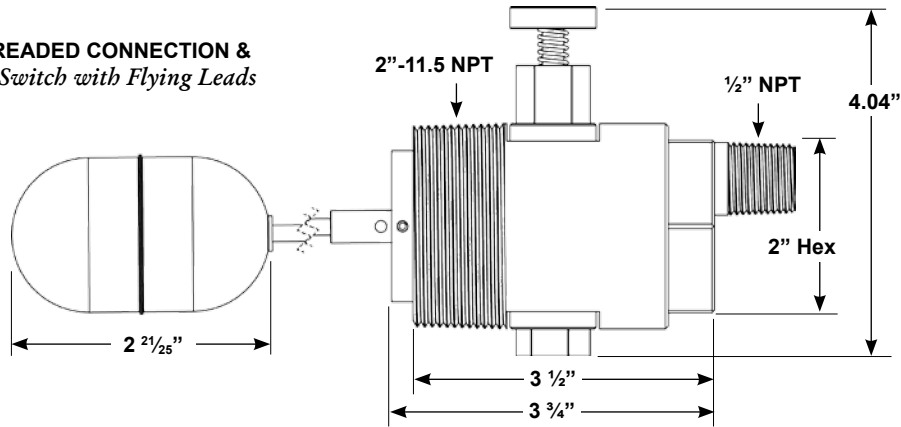

L072 WITH FLANGED CONNECTION & SPST or SPDT Switch with Flying Leads

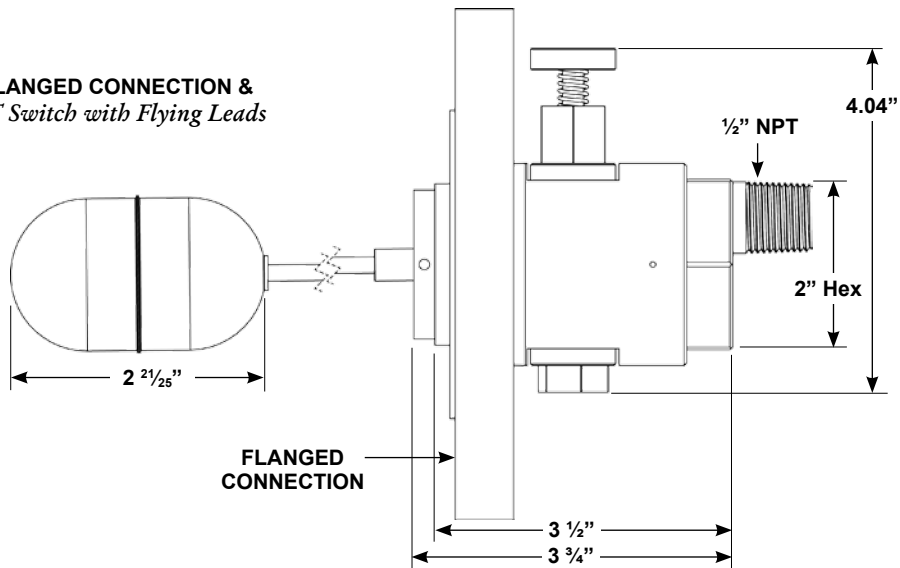

### 3.6 MODEL CONFIGURATOR

TECHNOLOGY		MODEL		CONFIG.		MOUNTING		HOUSING		FLOAT		ELECTRICAL & J-BOX	
L	Liquid Level Sensor	072	Side-Mount Level Switch	-	Standard	08	1 1/2" NPT	08	316/316L S.S.	30	Standard 316 S.S.	04	100 VA SPST & No J-Box
				C	Custom	09	2" NPT	10	Hastelloy C276	31	Extended 316 S.S.	07	30 VA SPDT & No J-Box
						54	1 1/2" BSPT Threaded			32	Standard Hastelloy C276	23	100 VA SPST & Pyromation #93 Box
						55	2" BSPT Threaded			33	Extended Hastelloy C276	24	30 VA SPDT & Pyromation #93 Box
						72	1 1/2" Flange #150			10	Adjustable Length Float Rod 316 S.S.	28	100 VA SPST & OZ Gedney GUAL-50 Box
						73	2" Flange #150					29	30 VA SPDT & OZ Gedney GUAL-50 Box
						74	2 1/2" Flange #150					31	24 VDC DPDT & OZ Gedney GUAL-50 Box
						75	3" Flange #150					32	120 VAC DPDT & OZ Gedney GUAL-50 Box
						76	4" Flange #150					38	100 VA SPST & OZ Gedney GUALB-75 Box
						83	1 1/2" Flange #300					39	30 VA SPDT & OZ Gedney GUALB-75 Box
						84	2" Flange #300					41	24 VDC DPDT & OZ Gedney GUALB-75 Box
						85	2 1/2" Flange #300					42	120 VAC DPDT & OZ Gedney GUALB-75 Box
						86	3" Flange #300						
						87	4" Flange #300						

L
0
7
0
-
0
8
0
8
-
3
0
0
4

---

## 3.7 NOTES

# ASSURED QUALITY & SERVICE COST LESS

## Service Policy

Owners of Solutions With Innovation products may request a return of the product, or any part of the product for complete rebuilding or replacement. Units will be rebuilt or replaced promptly. Products returned under the SWI Service Policy must be returned by prepaid transportation. Solutions With Innovation will repair or replace the product at no cost to the purchaser (or owner) other than transportation if:

- 1 Returned within the warranty period; and
- 2 Factory Inspection finds the cause of the claim to be covered under the warranty.

If the problem is due to circumstances beyond Solutions With Innovation's liability, or is NOT covered by the warranty, there will be charges for labor in addition to the parts required to rebuild or replace the equipment.

In rare cases, it may be expedient to ship replacement parts; or in extreme cases, an entire product before the damaged product is returned. If a quick replacement service is necessary, notify the manufacturer of the damaged product's model and serial number. In such cases, credit for the returned materials will be determined on the applicability of the warranty.

No claims for misapplication, labor, direct or consequential damage will be allowed.

## Return Material Procedure

In order to efficiently process any returned materials, it is essential that a *Return Material Authorization* (RMA) number be obtained from the manufacturer prior to an item's return. RMA's can be issued through local representatives, or by contacting the factory directly.

Please supply the following information:

- 1 The Company's Name
- 2 Description of the Material
- 3 Product Serial Number
- 4 Reason for Return
- 5 Product's Application

Used units must be properly cleaned in accordance with OSHA standards before it is returned to the manufacturer. A *Material Safety Data Sheet* (MSDS) must accompany units or materials that were used in any type of media. All return shipments to the factory must be by done via prepaid transportation. All product replacements will be shipped F.O.B. manufacturer.



**SOLUTIONS WITH INNOVATION**

AN INNOVATIVE SENSING COMPANY

ISO 9001:2008 CERTIFIED

BULLETIN: IS-8150.3  
EFFECTIVE: 10/16

